

Crio Line SB 2 Door Refrigerated Counter (R290)

ITEM # _____

MODEL # _____

NAME # _____

SIS # _____

AIA # _____



712418 (AJ2HBAA)

2-door refrigerated counter, -2/+10°C, AISI 304 (R290)

Short Form Specification

Item No. _____

AISI 304 stainless steel panels, AISI 430 bottom panel, galvanized back panel. Worktop thickness 50mm. N. 2 full doors. Built-in refrigeration unit. Operating temperature: -2/+10°C. R290 gas in refrigeration circuit. Supplied with 1 grid for each door compartment

Main Features

- Certified safety CE requirements.
- Adjustable temperature range from -2 °C to +10 °C to suit meat, fish and dairy storage requirements.
- Tropicalized unit (43°C ambient temperature).
- 0mm clearance installation space: tower configuration cooling unit guarantee performance with frontal ventilation only; this unique solution allows installation against the wall or side by side with other appliances, even on the cooling unit side to maximize the use of kitchen space.
- Combination of doors and drawers to suit any configuration needed, with the possibility to change the configuration on site. Right cooling unit available on request.
- Frontal and easy access to all components in the cooling unit.
- Fully compliant HACCP digital control: when temperature exceeds critical limits, acoustic and visual alarms are activated. Up to two months of event are kept in memory.
- Anti-tilt runners accept GN 1/1 containers.
- Self closing stainless steel doors (< 90°).
- Prearranged to fit RS485 port to facilitate connection to a remote computer and integrated HACCP systems.
- Hot gas automatic evaporation of defrost water.
- Combination of doors and drawers to suit varying needs, with the possibility to change the configuration on site.
- Digital control panel.
- Forced air circulation for rapid cooling and an even temperature distribution.
- Refrigerated compartment designed to accept GN 1/1 containers.
- Preservation performances and temperature uniformity within the cell guaranteed at 5-HEAVY DUTY (40°C) working conditions according to EN16825:2016 test protocol.
- Mounted on stainless steel feet to give 150 mm (-5/+50 mm) clearance for ease of cleaning the floor.
- Small footprint to fit even in limited environments.
- Large digital white-digit display with humidity selection button (3 preset level), internal temperature display and setting, manual activation of defrost cycle and turbo frost cycle (to rapidly cool warm loads).
- Equipped with Optiflow forced air circulation system for rapid cooling and temperature distribution within the cell.
- Fully removable cooling unit to facilitate maintenance.
- Digital control panel allowing the easy and precise setting and control of the internal temperature.
- Operating temperature can be adjusted from -2 to +10 °C to suit different food storage requirements.
- Complies with main international certification bodies and is CE marked.
- Kit 1/2 drawers available as accessory.
- The door self-closes when opened less than at a 90° angle and is equipped with a door seal to guarantee perfect closure.
- Completely automatic defrosting and automatic evaporation of defrost water by hot gas.
- Forced air cooling system guaranteeing great uniformity of the temperature in the counter and excellent conservation of the food quality.
- High standards of hygiene and ease of cleaning are guaranteed by the rounded internal corners of the cabinet and easily removable runners and grids.

APPROVAL: _____

- Kit 1/3 drawers available as accessory.
- Connectivity ready for real time access to connected appliances from remote and data monitoring (requires optional accessory).
- Easy serviceability thanks to the intuitive control panel with remote access via app.
- Integrated RS485 port to facilitate connection to a remote computer and integrated HACCP systems.
- Internal structure with numerous charging positions available to host grids, ensuring higher net capacity and a greater storage space.
- External bottom panel in stainless steel.
- External back panel in galvanized steel.

Construction

- Built-in compressor to suit operating conditions.
- Interior base with rounded corners, pressed from a single sheet.
- Ease of cleaning and high hygiene standards thanks to the rounded internal corners, the easily removable runners, grids and air conveyors.
- Internal structure with 15 charging positions (3 cm pitch) available to host GN 1/1 grids, ensuring higher net capacity and a greater storage space.
- Built-in refrigeration unit.
- Developed and produced in ISO 9001 and ISO 14001 certified factory.
- Fault code display.
- Access to all components from the front.
- Internal and external doors, front, back and side panels in AISI 304 Stainless steel.
- Mounted on Stainless steel adjustable legs to give 150 mm clearance for ease of cleaning.
- Rounded internal corners for ease of cleaning.
- Pre-arranged for drain-pipe.
- Extractable cooling unit to facilitate maintenance.
- IP21 protection index.
- Internal and external doors, front and side panels and removable worktop in AISI 304 Stainless steel.
- External back panel in galvanized steel.
- Legs in 304 AISI stainless steel (150 mm high, adjustable in height), with plastic interior.
- Insulation guaranteed by high density expanded cyclopentane 50 mm in thickness.
- Internal and external doors, front and side panels and 50mm thick removable worktop in 304 AISI stainless steel.

Included Accessories

- 2 of Kit 1/1GN gray rilsan grid and 2 side runners for refrigerated counters PNC 881109

Optional Accessories

- 1/1GN gray rilsan grid for refrigerated counters PNC 881107
- 2 side runners for 1/1GN refrigerated counters PNC 881108
- Kit 1/1GN gray rilsan grid and 2 side runners for refrigerated counters PNC 881109
- 1/1GN plastic container, h65mm PNC 881110
- 1/1GN plastic container, h100mm PNC 881111
- Worktop for refrigerated Crio Line CP and SB counters - 2 compartments PNC 881124

- Worktop and upstand for refrigerated Crio Line CP and SB counters - 2 compartments PNC 881127
- 2x1/2-drawer kit for refrigerated counters - h650mm PNC 881176
- 3x1/3-drawer kit for refrigerated counters - h650mm (only for refrigerated counters) PNC 881177
- 1/3 and 2/3 bottle drawer kit for refrigerated counters - h650mm (only for refrigerated counters) PNC 881178
- Kit 4 wheels, h100mm (2 with brakes) for refrigerated counters PNC 881191
- Kit 4 wheels, h150mm (2 with brakes) for 2&3 compartment refrigerated counters PNC 881193
- Lock for refrigerator/freezer counters with 2 compartments - h650mm PNC 881245
- Kit 4 (45mm) spacers for wheels for refrigerator/freezer counters PNC 881277

Front

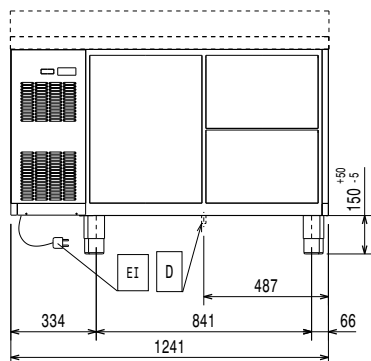

Side

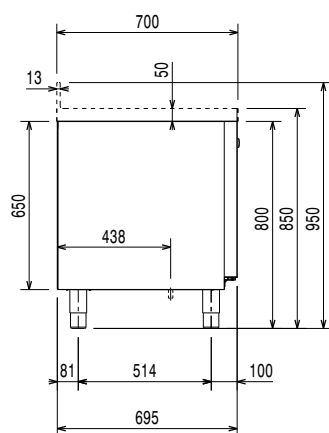

EI = Electrical inlet (power)

Top

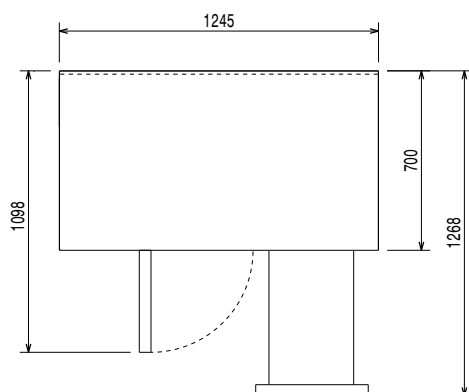

Electric

Supply voltage:	712418 (AJ2HBAA)	220-240 V/1 ph/50 Hz
Electrical power max.:		0.22 kW

Key Information:

Gross capacity:	290 lt
Net Volume:	163.6 lt
N° of doors:	
External dimensions, Width:	1245 mm
External dimensions, Depth:	700 mm
External dimensions, Height:	850 mm
Internal Dimensions, Width:	798 mm
Internal Dimensions, Depth:	560 mm
Internal Dimensions, Height:	510 mm
Net weight:	94 kg
Shipping volume:	1.08 m ³
Depth with doors open:	1310 mm
Height adjustment:	-5/50 mm

Refrigeration Data

Control type:	Digital
Compressor power:	1/4 hp
Min/Max internal humidity:	40/85
Operating temperature min.:	-2 °C
Operating temperature max.:	10 °C
Operating mode:	Ventilated

Sustainability

Energy Class (EU Reg. 2015/1094):	B
Yearly and daily energy consumption (EU Reg. 2015/1094):	560kWh/year - 2kWh/24h
Climate class (EU Reg. 2015/1094):	Heavy Duty (5)
Energy Efficiency Index-EEI (EU Reg. 2015/1094):	25,36
Refrigerant type:	R290
GWP Index:	3
Refrigeration power:	320 W
Refrigerant weight:	50 g

EU energy labelling from 1st July 2016

The European energy labelling scheme for professional refrigerators and freezers is based on requirements setting Minimum Energy Performance standards for commercial refrigeration cabinets sold within the EU. These requirements are designed to drive energy efficiency and environmentally friendly approach for professionals. The European energy labelling scheme will apply to all manufacturers and importers who sell and market products within the EU and it is mandatory across Europe. Important: all products which consume energy above the minimum level will not be able to be sold within the EU from 1 July 2016.

SI 2020 No. 1528.

Important: all products which consume energy above the minimum level will not be able to be sold within the EU from 1 July 2016.

